

Functional analysis (CU6)

Mark Cropper
Celine DelleLuche
Claude Huc
David Katz
Anne Jean-Antoine
Thierry Levoir
Michel Nonon-Latapie
Frédéric Thévenin

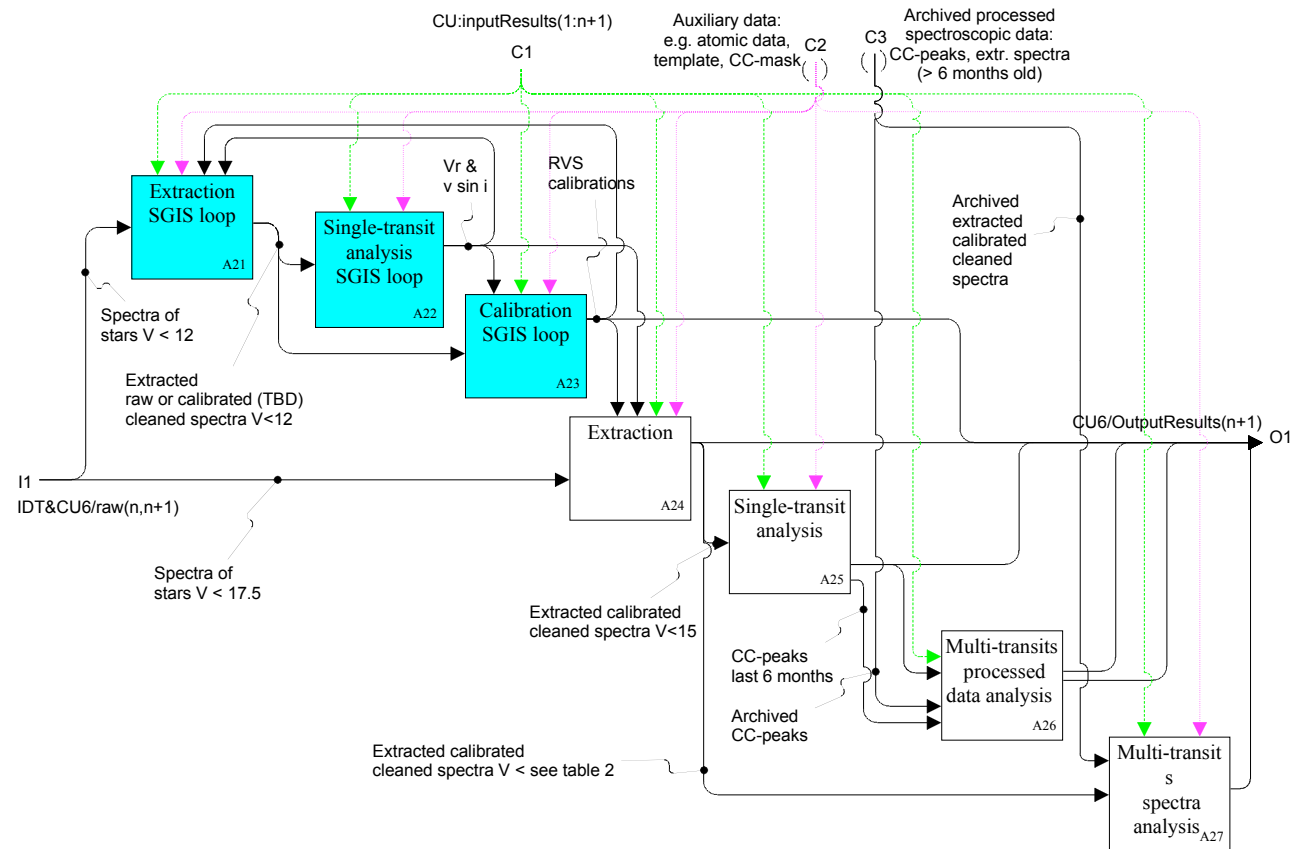

Paris, 6-7 mars 2006

Functional Analysis of Gaia

- General purpose : overview of the data reduction chain
- Data flow and time sequence
- Developed with the SADT tool
- First one developed in 2005 cover all CUs with more or less complexities : published on livelink GAIA-C1-TN-OCA-FT-001-1
(First version Mostly developed around CU6 and CU8 activities)

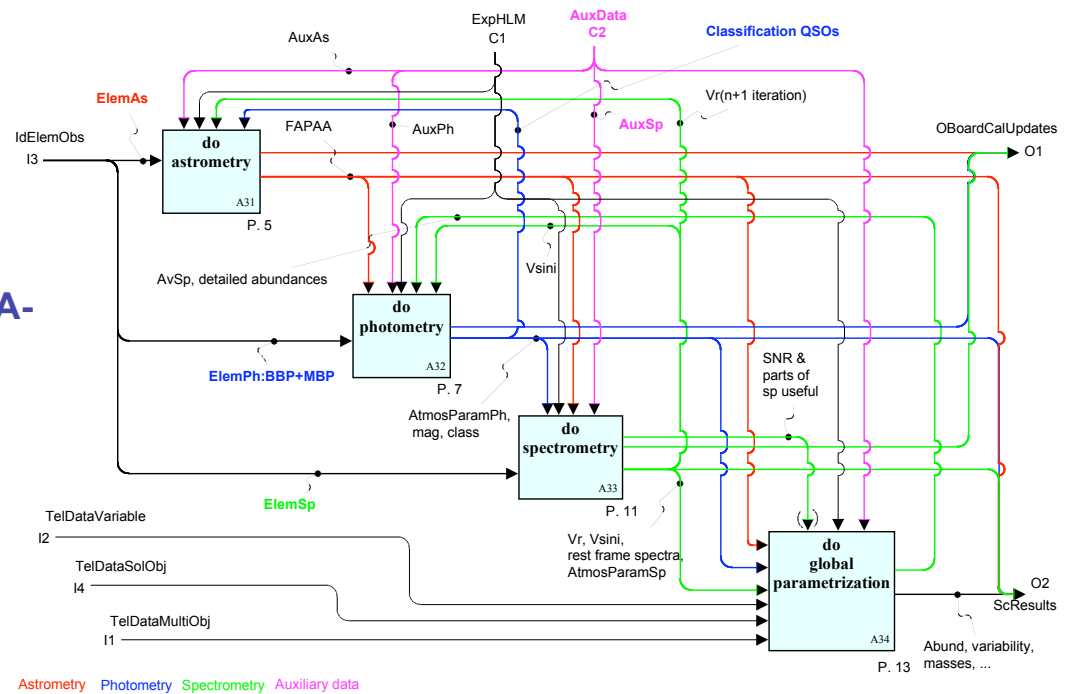

A new version in preparation for CU4, CU6 and CU8

Paris, 6-7 mars 2006

Functional Analysis CU6

- Context diagram : to define the environment

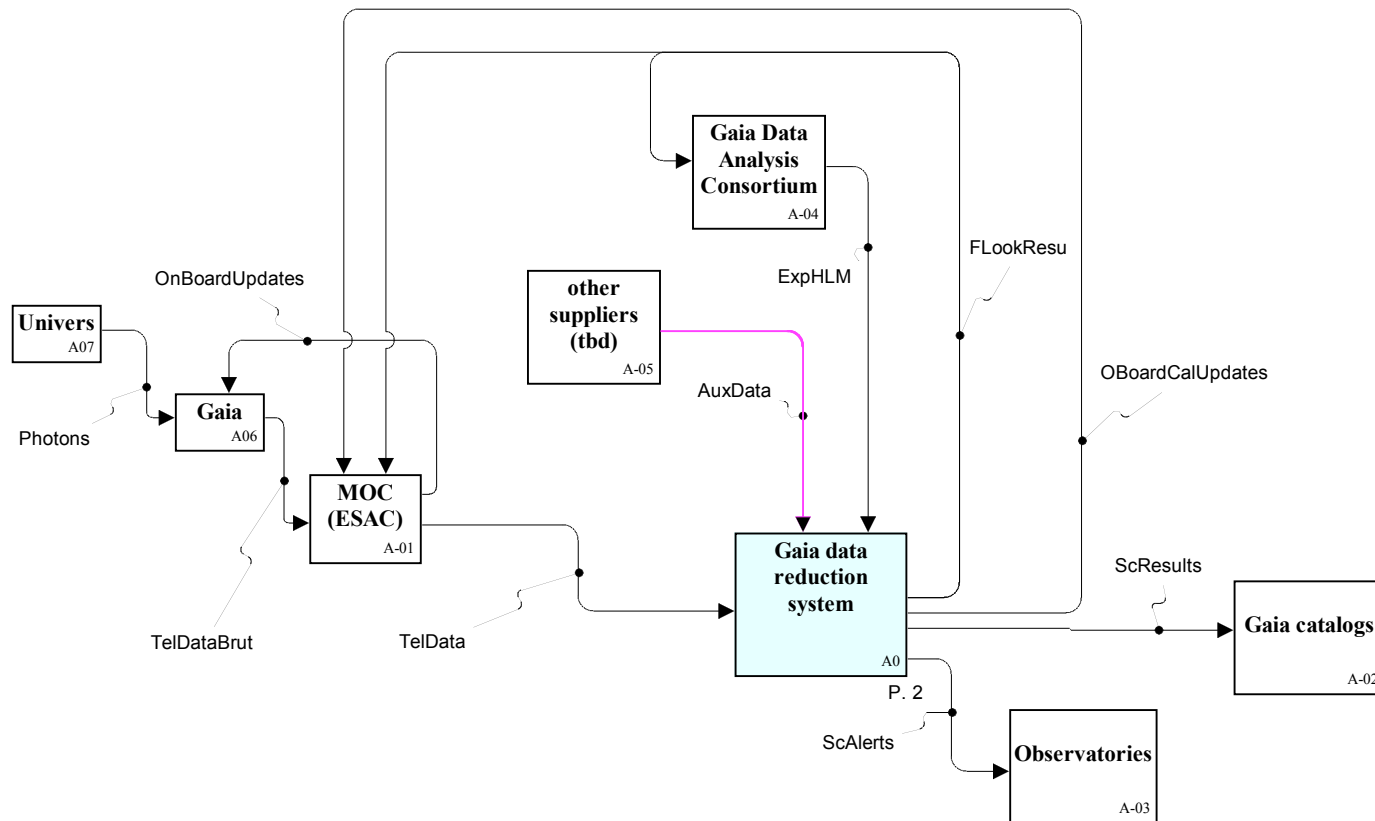

Functional Analysis CU6

- Has to be organized with a chronogram

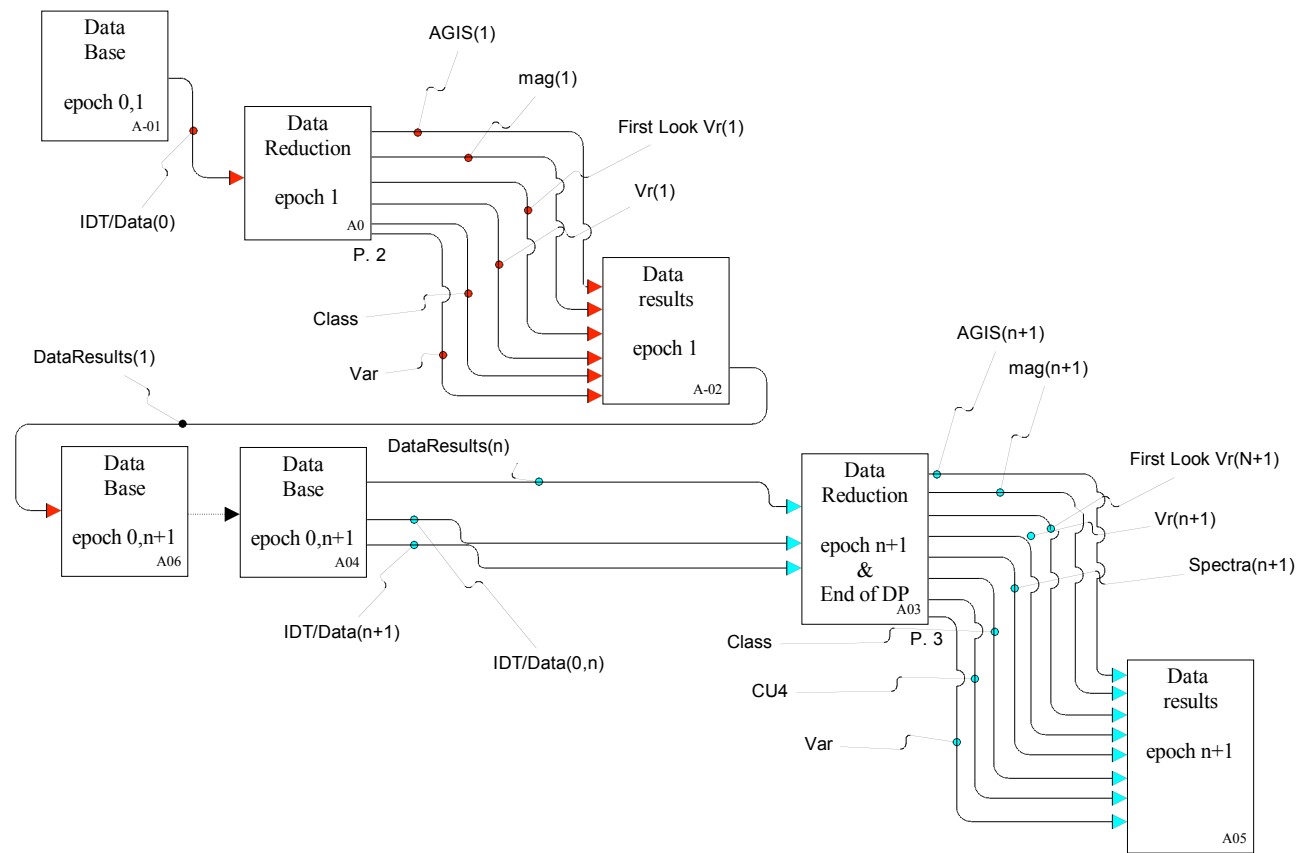

Paris, 6-7 mars 2006

Functional Analysis CU6

- What we have to do?
- To extract from raw data the spectra
- To clean the spectra
- To calibrate the RVS and the spectra
- To derive a V_r and eventually V_{rot}

The input list per object

(with their uncertainties and quality flags)

- Astrometric parameters (CU3)
RA and dec, proper motion for SolSYsObj
- Photometric parameter (CU5)
magnitudes at the time of observation: from IDT CU3 or could be processed by CU5, variability from CU5/7
- Classification parameters with their probabilities (CU8)
param for selection of template (Teff, logg, Z)
object class: solsysobj, QSO, single star, binary, extended object etc.
- CU6 parameters-library inputs
previous RVS data (internal CU6), synth data, cross-correlation masks, external standards (RV, spectro-photometric)
- CU6 inputs
internal to CU6: **what does it means?**

CU6 inputs

internal to CU6: **what does it means?**

- **Daily processing:**
 1. spectroscopic processing raw data
 2. IDT/Data associated with spectro like sky mapper data daily transfer, and CU6 list as above, most recent calibration files
- **Half-yearly processing:** same
- **Post mission end of processing:** same

CU6 output

- **Daily** : updated calibration (instrumental)
updated star calibrators
new spectra
faint star sanity
radial and rotational velocities diagnostics
calibration trends, triggers, alerts (from sanity)
- **Half-yearly**: update the stars calibrator status
- **Post mission end processing**: update the stars calibrator status

Traitments

- **Multi-transit Analysis**
 1. Process data coming from the single transit: cross-correlation products. Skew processing?
 2. Multi transit spectral data analysis works on the individual spectra which could be shifted in wavelength space before co-adding.

Traitments

- Calibration/SGIS
- In daily calibrations, the model is updated.
- The SGIS occurs in a loop of 6 months?, the calibration of the parameters from the instrument are re-derived by refining both the calibration applied to the calibration of the star observations (reanalysis of the observations) and the model at the same time, iteration.

(doc: GEPI/Gaia-RVS/TN/018.01)

- Size of the sample used by SGIS: affect the frequency of the re-run of the SGIS (Time between to consecutive SGIS run? In order to correct model for significant systematic effects)

Functional Analysis CU6

- Proposed chronogram for CU6 and related flows
- Periods of 6 months
- Daily and half yearly data treatment
- Relation with CU4, 7, 8 (tbd)

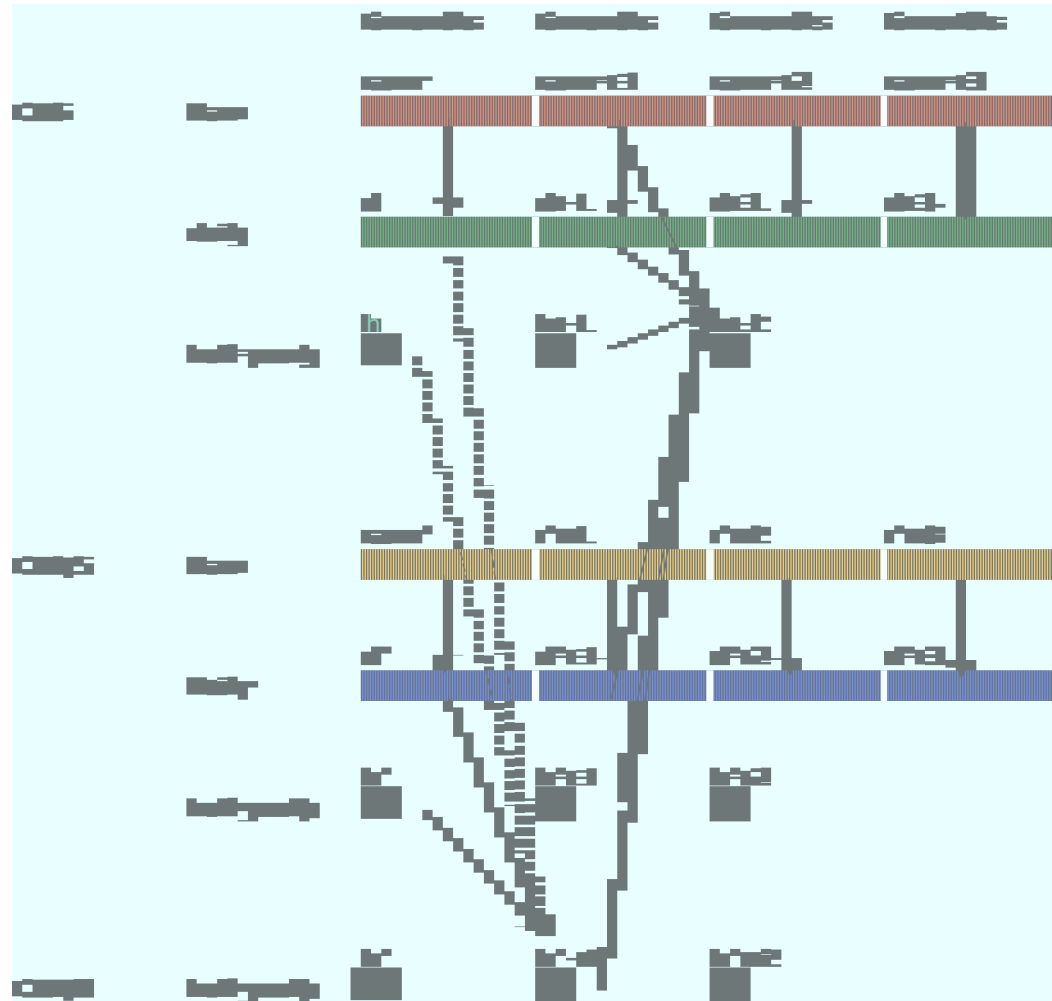

Paris, 6-7 mars 2006

Functional Analysis CU6

- Has to be organized with a chronogram

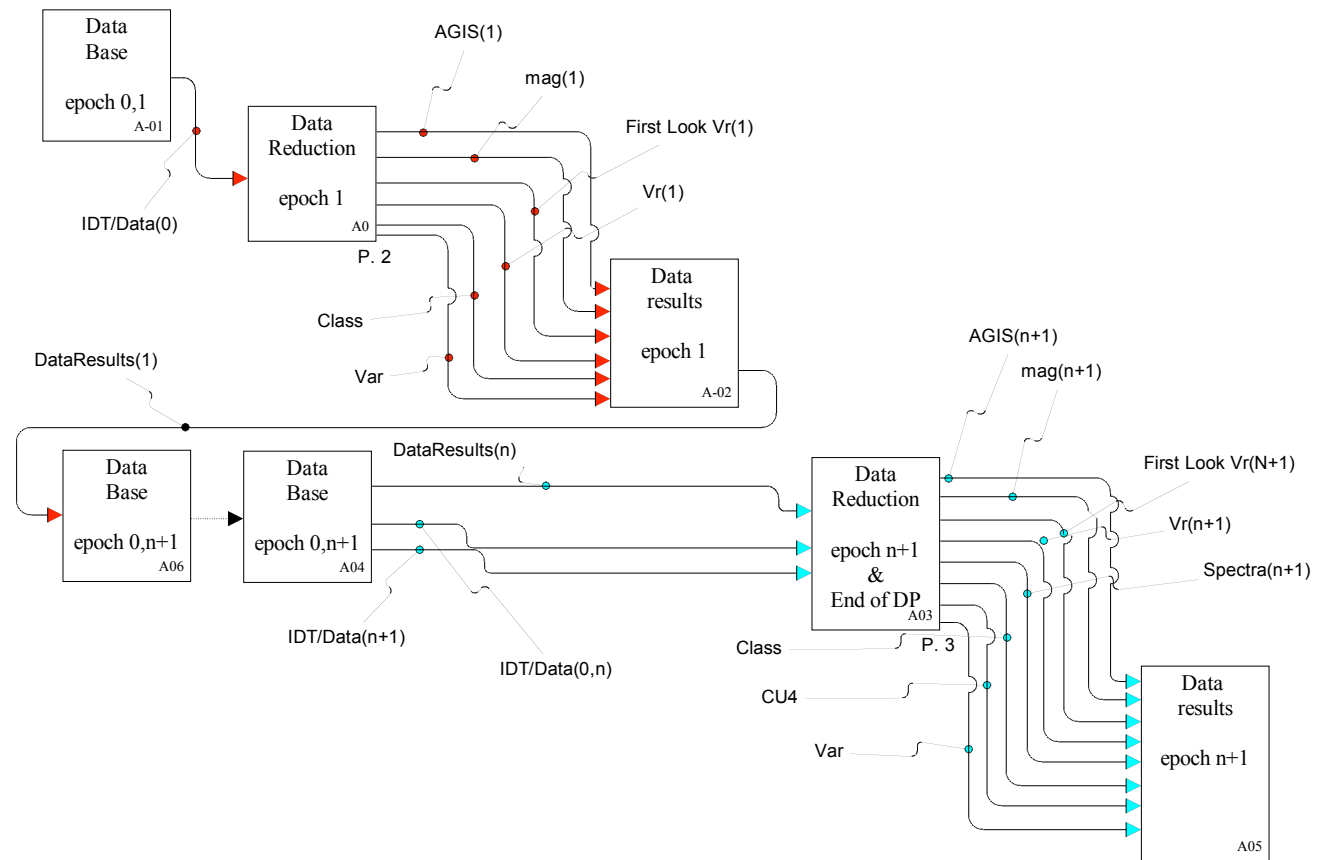

Functional Analysis CU6

epoch 1

- Relations with other CUs

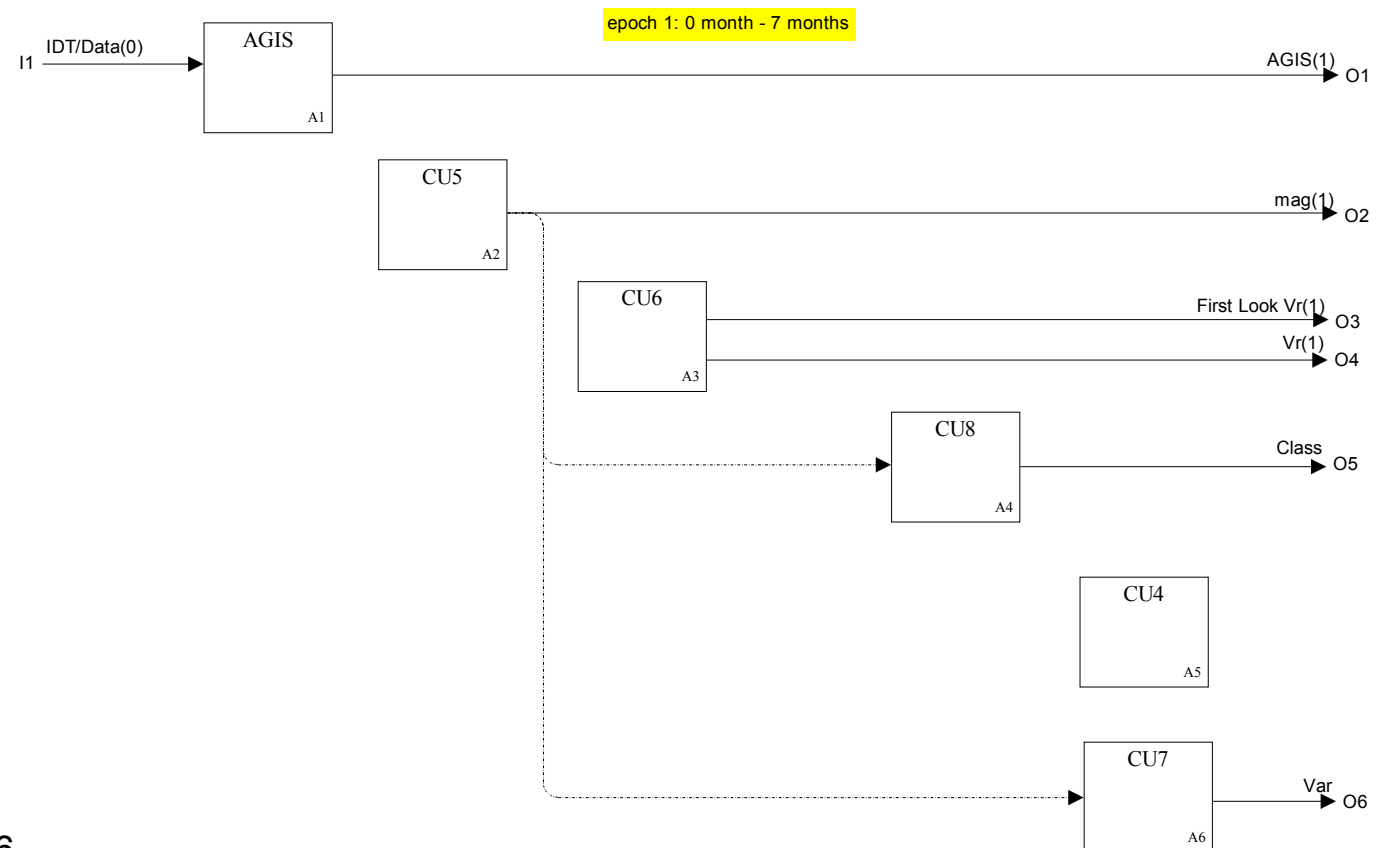

Paris, 6-7 mars 2006

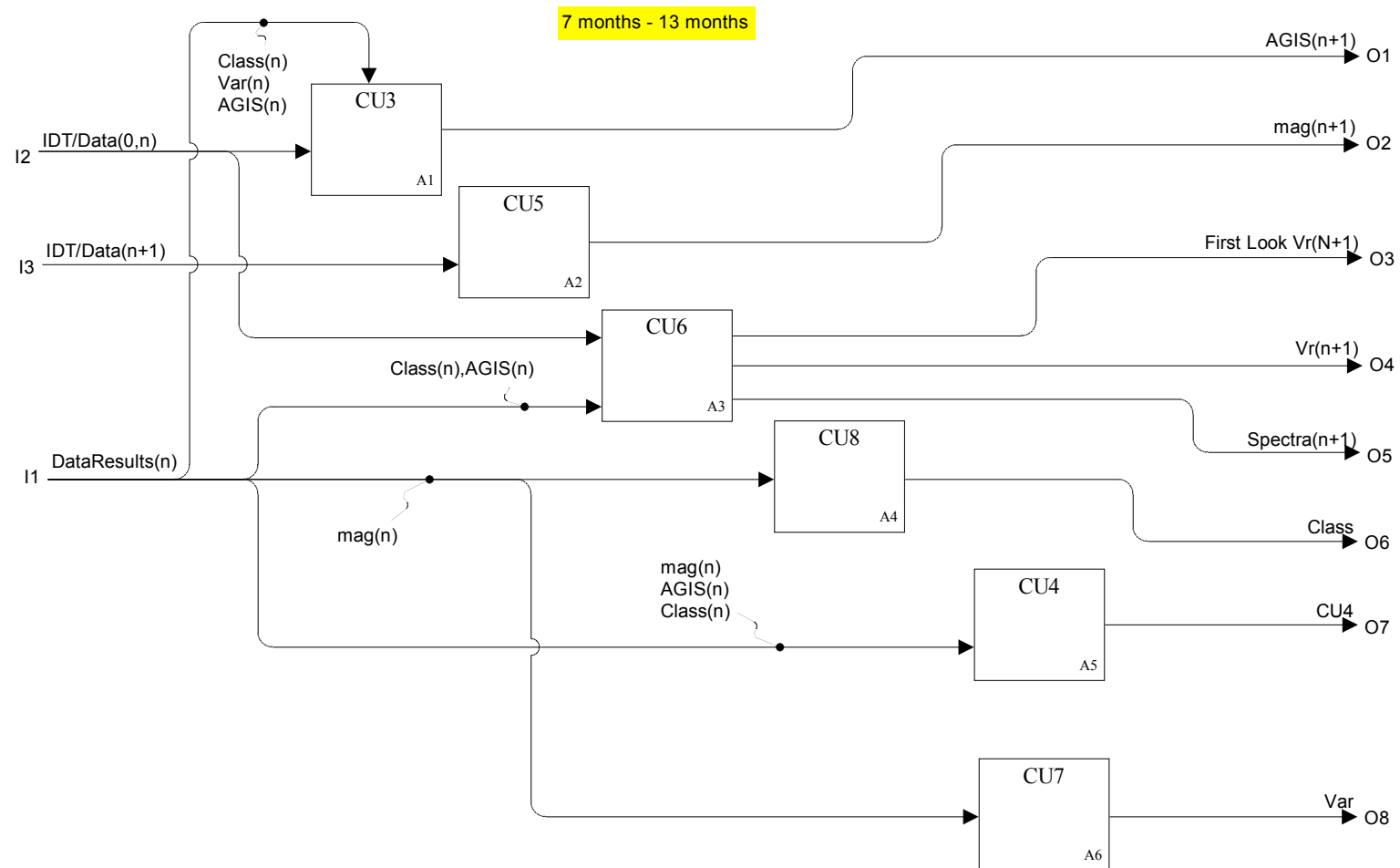

Paris, 6-7 mars 2006

Functional Analysis CU6

- The case of CU6

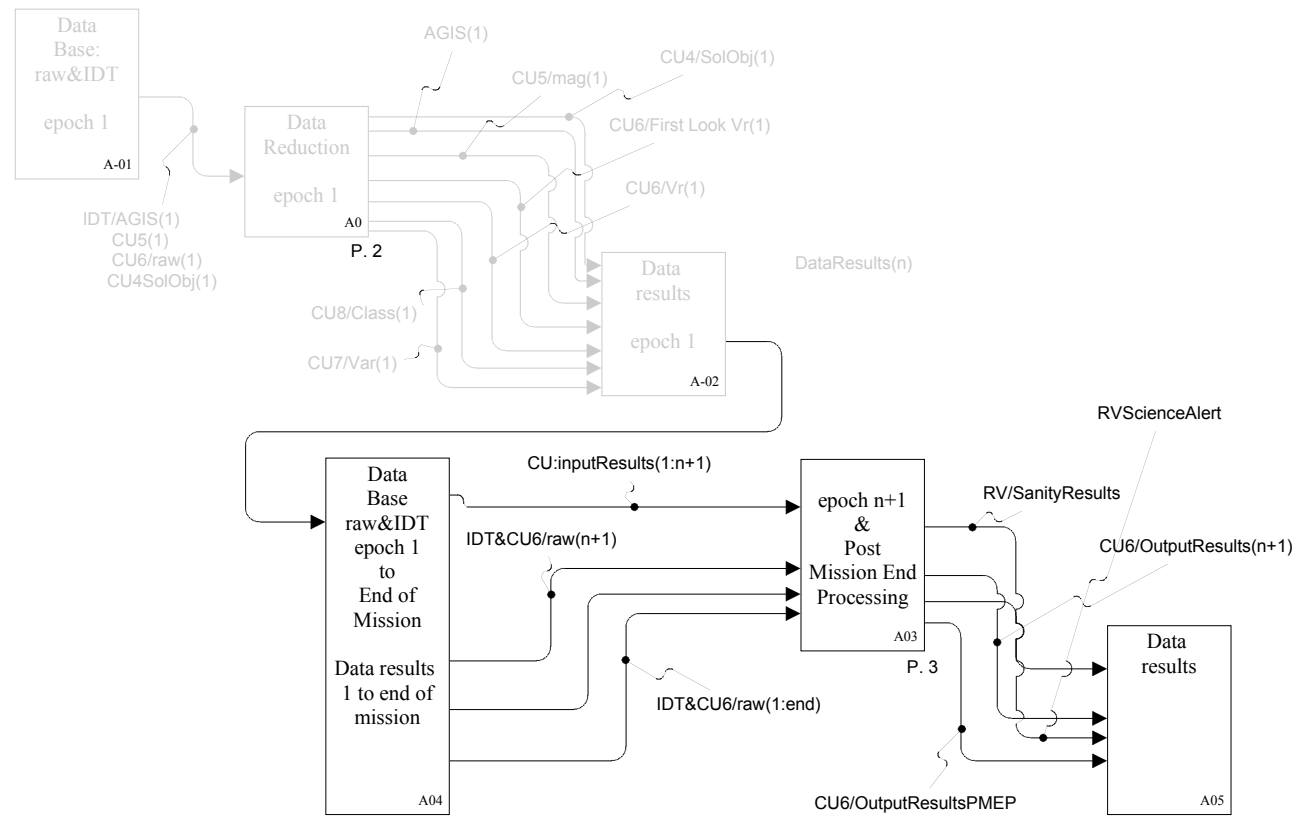

Paris, 6-7 mars 2006

Functional Analysis CU6

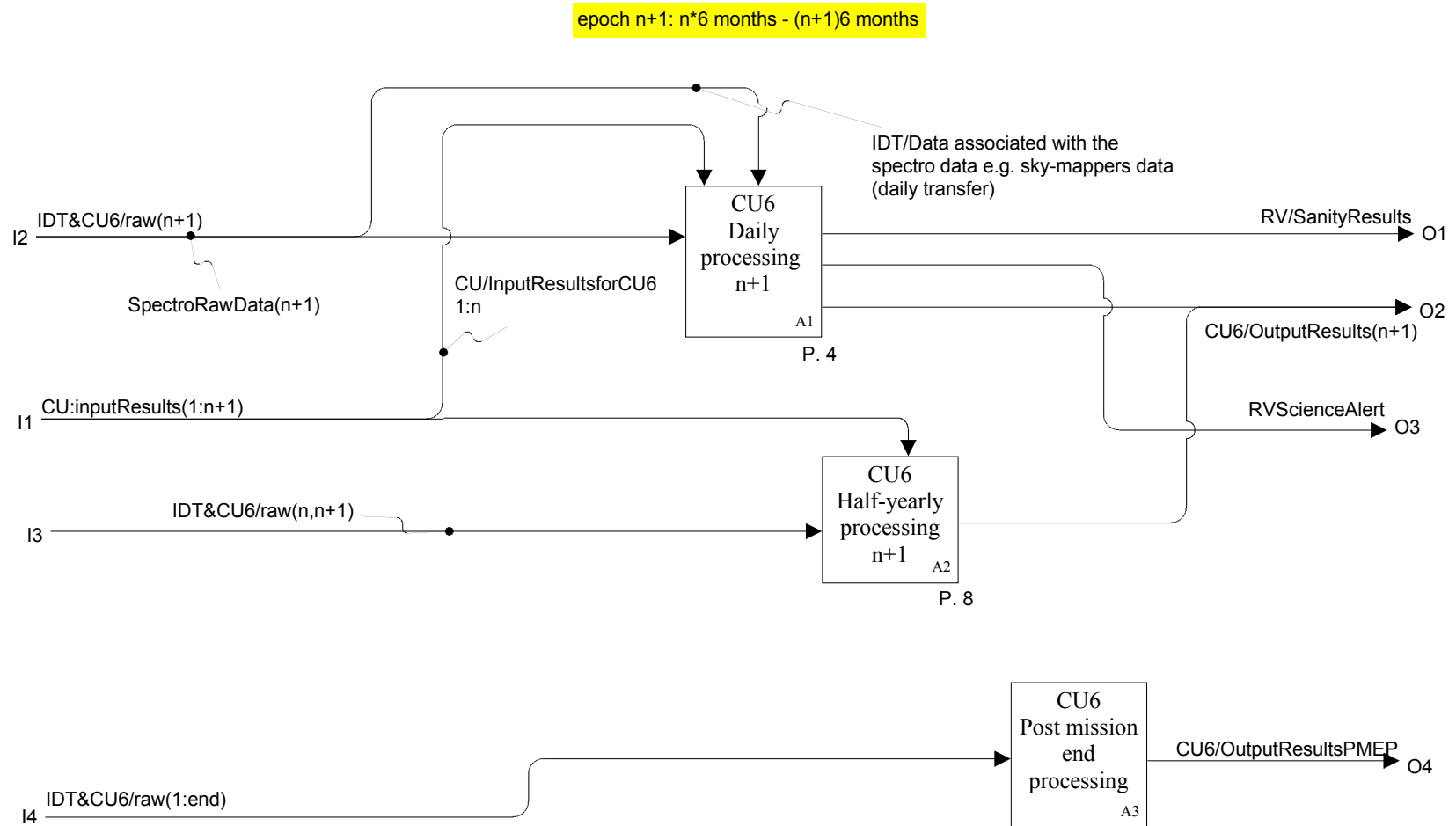

Paris, 6-7 mars 2006

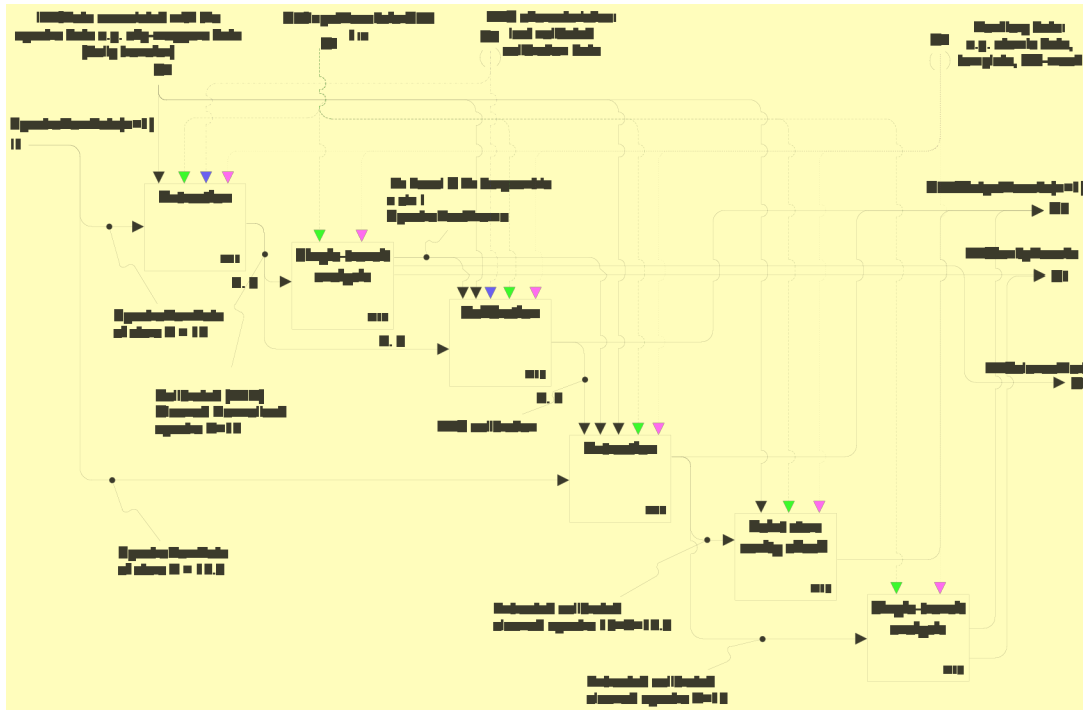

Functional Analysis CU6

epoch n+1: daily processing

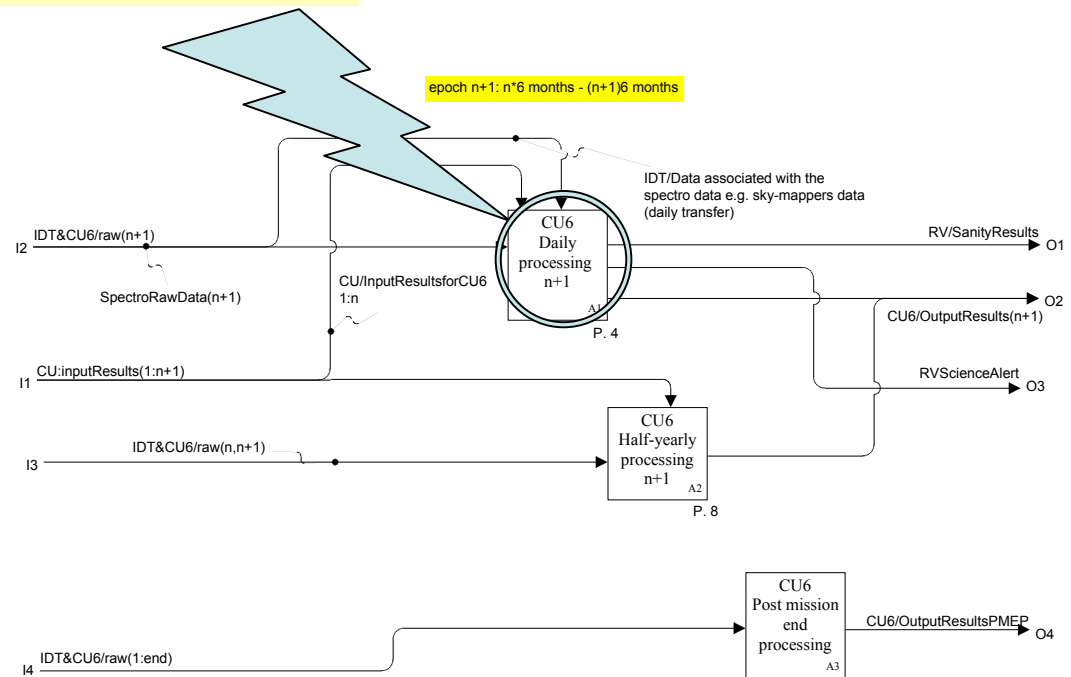

Paris, 6-7 mars 2006

Functional Analysis CU6

Epoch n+1: daily processing

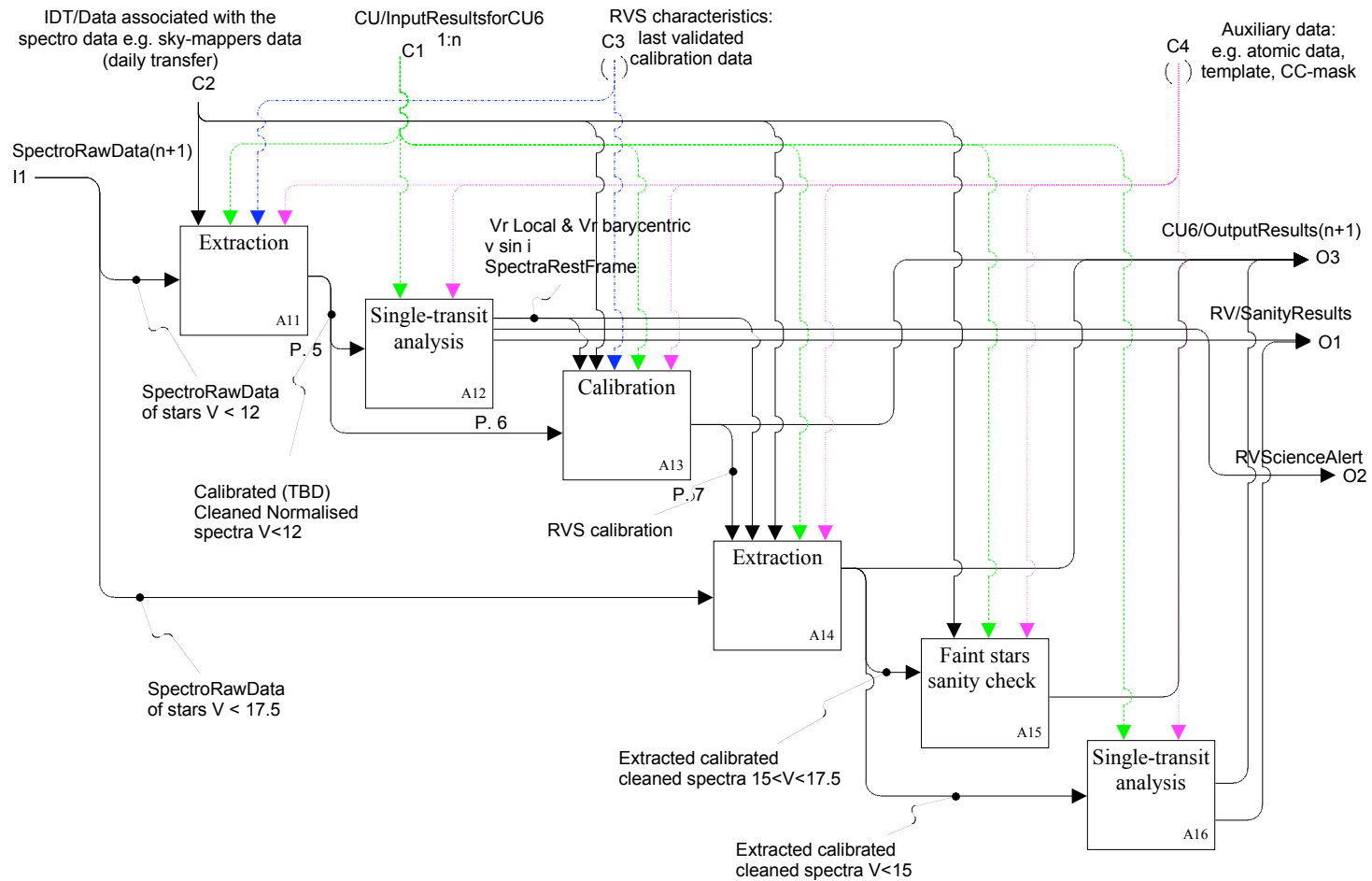

Paris, 6-7 mars 2006

Functional Analysis CU6

Epoch n+1: daily processing

EXTRACTION

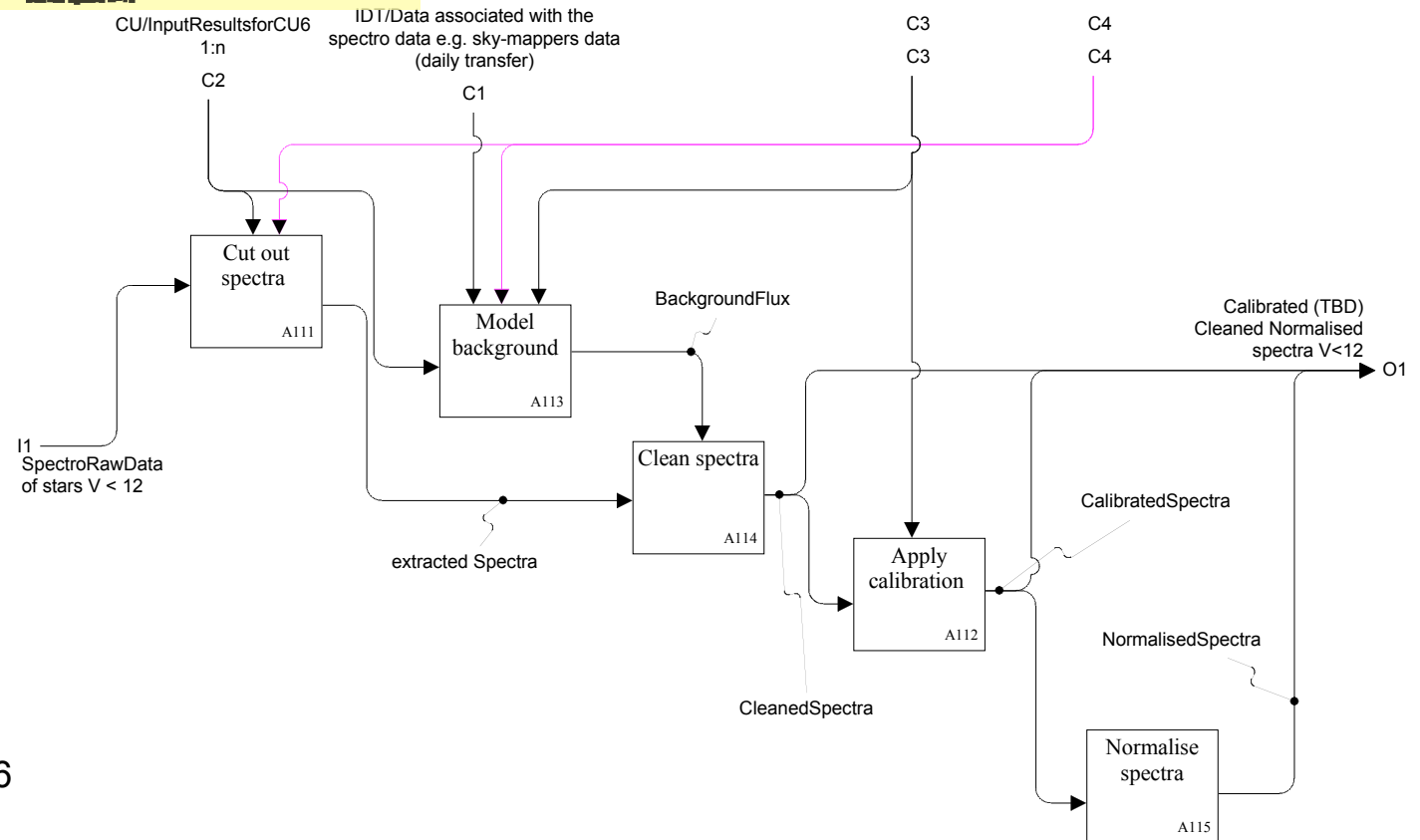
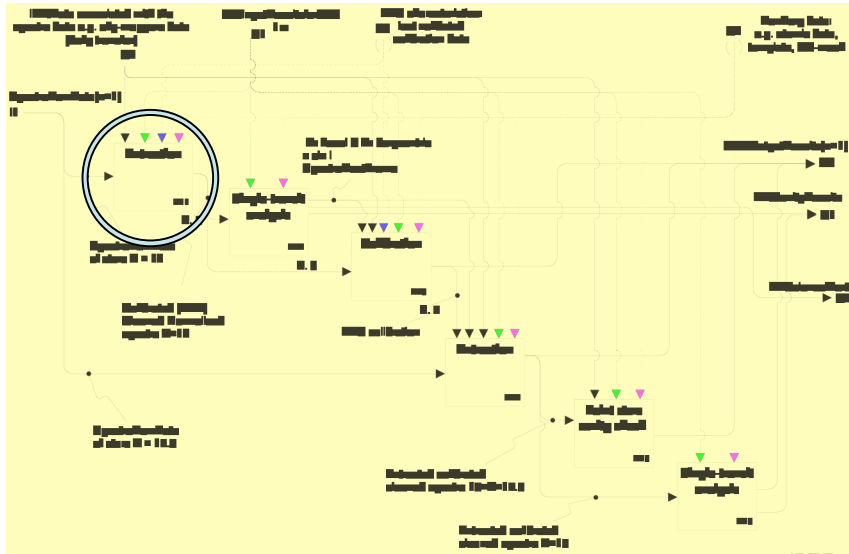

Paris, 6-7 mars 2006

Functional Analysis CU6

Epoch n+1: daily processing

SINGLE TRANSIT

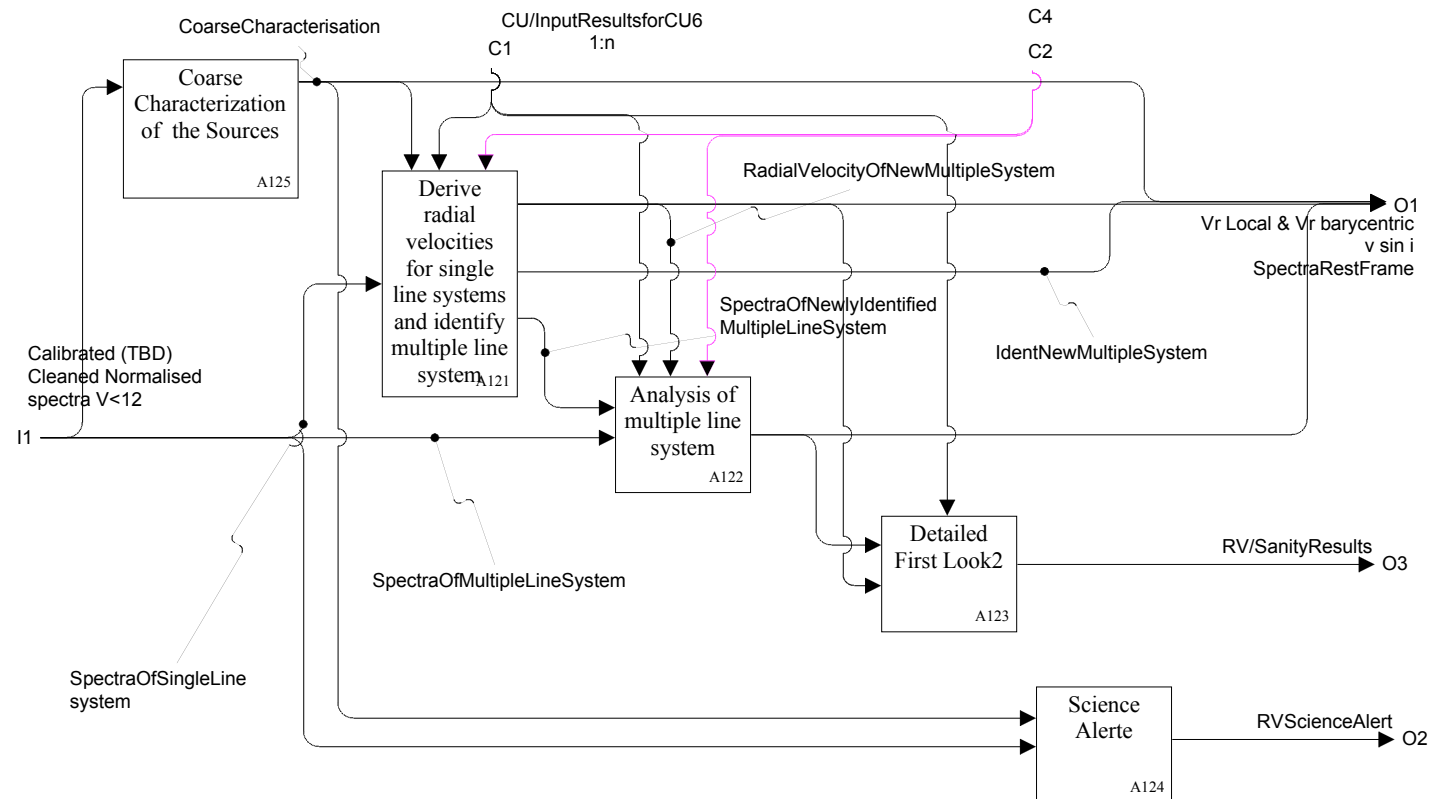
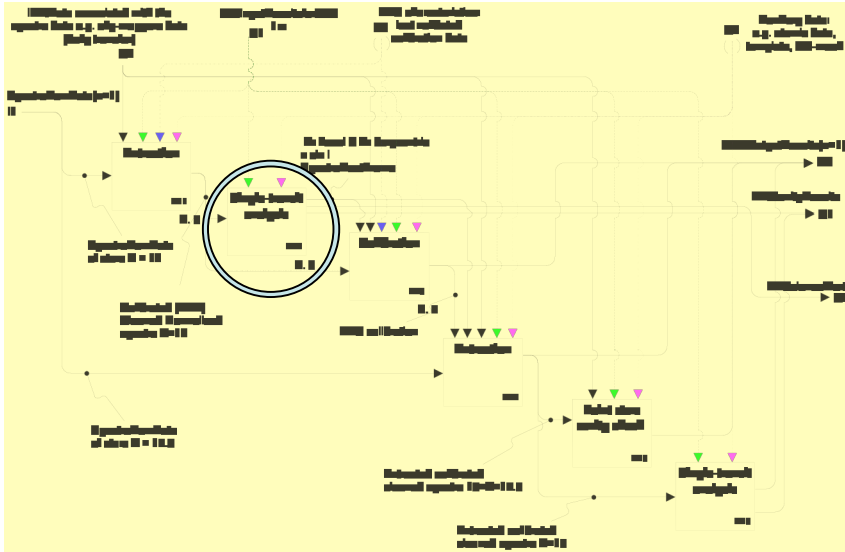

Paris, 6-7 mars 2006

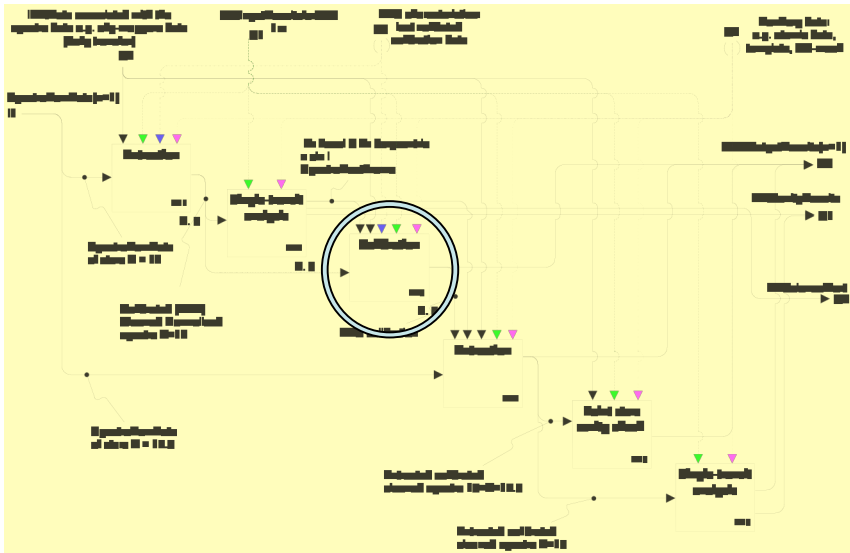

Functional Analysis CU6

Epoch n+1: daily processing

CALIBRATION

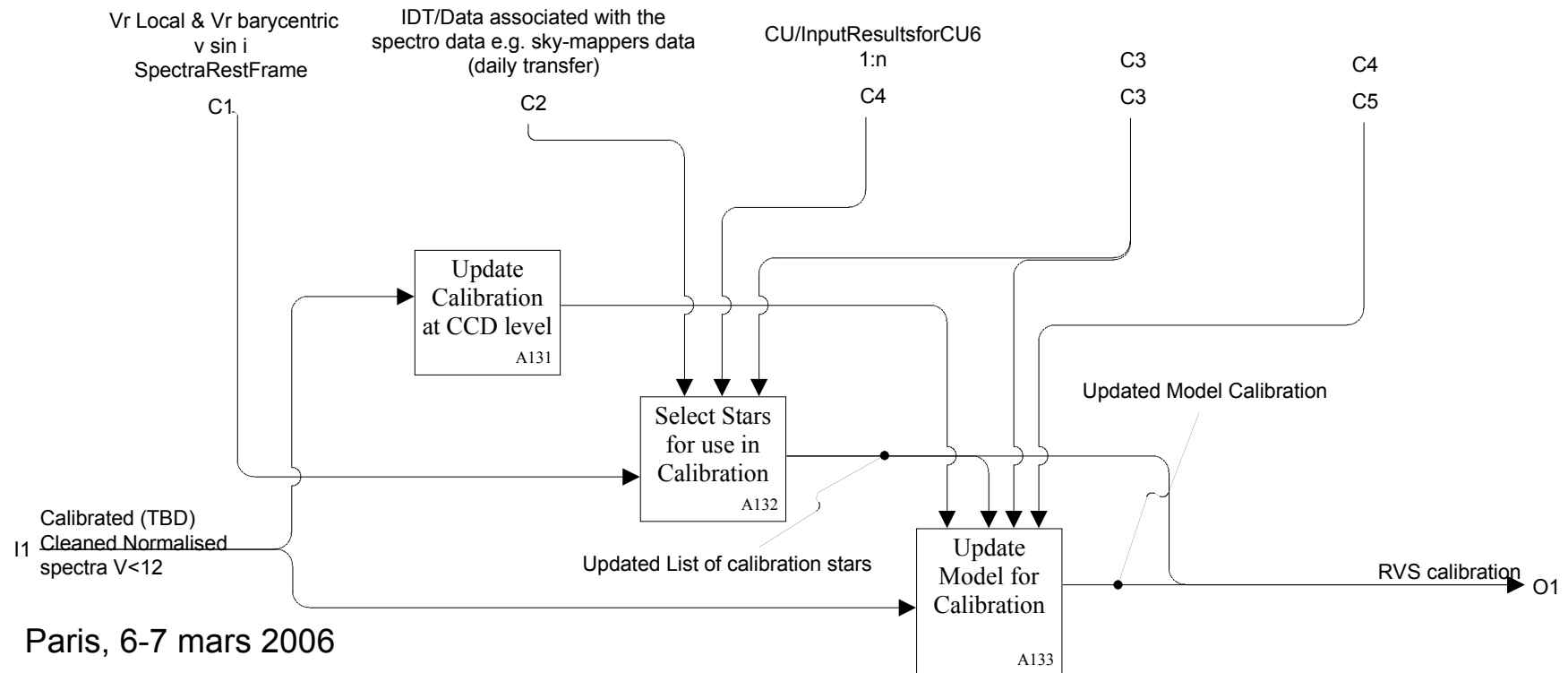

Functional Analysis CU6

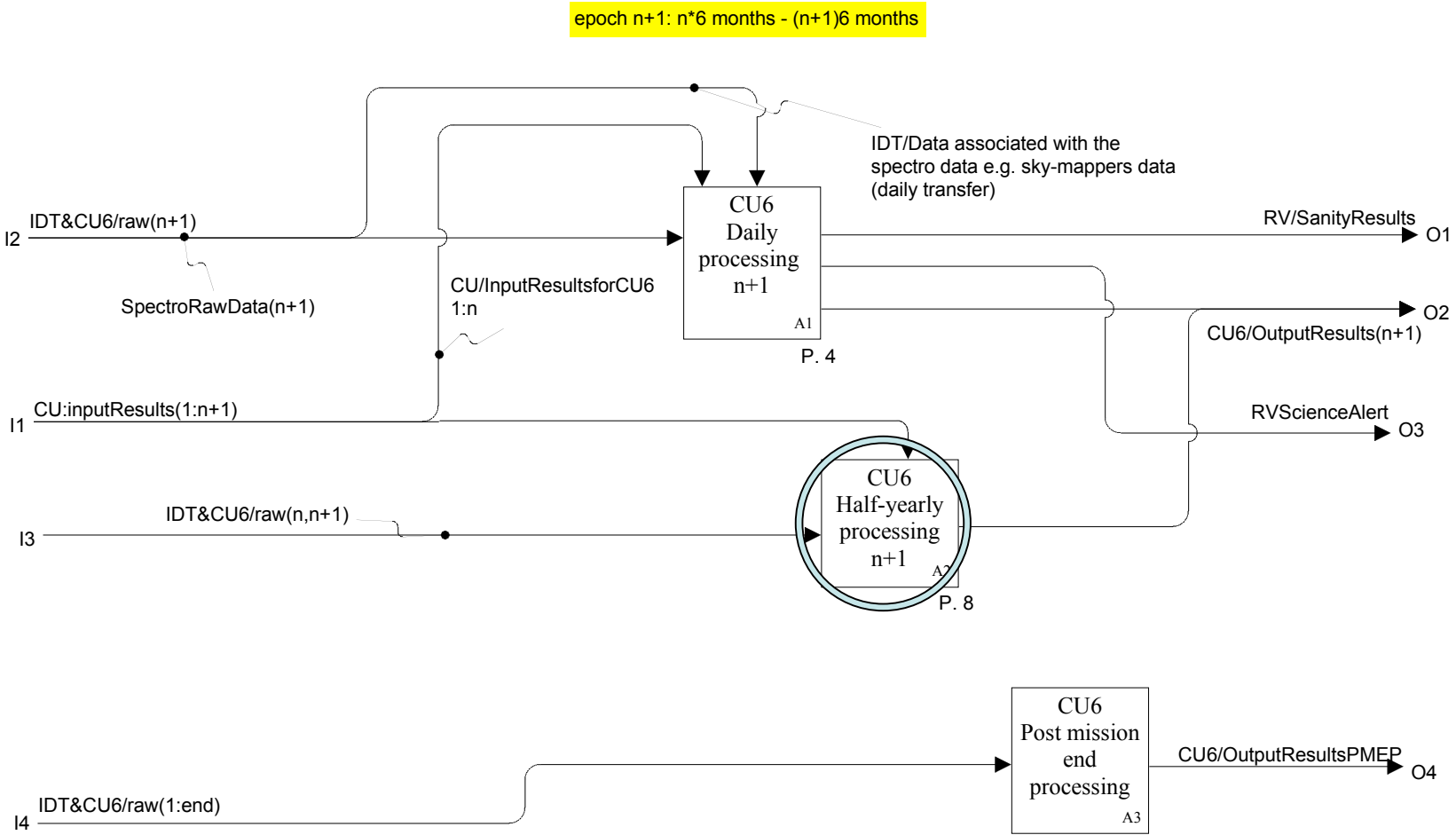

Functional Analysis CU6

Half yearly processing

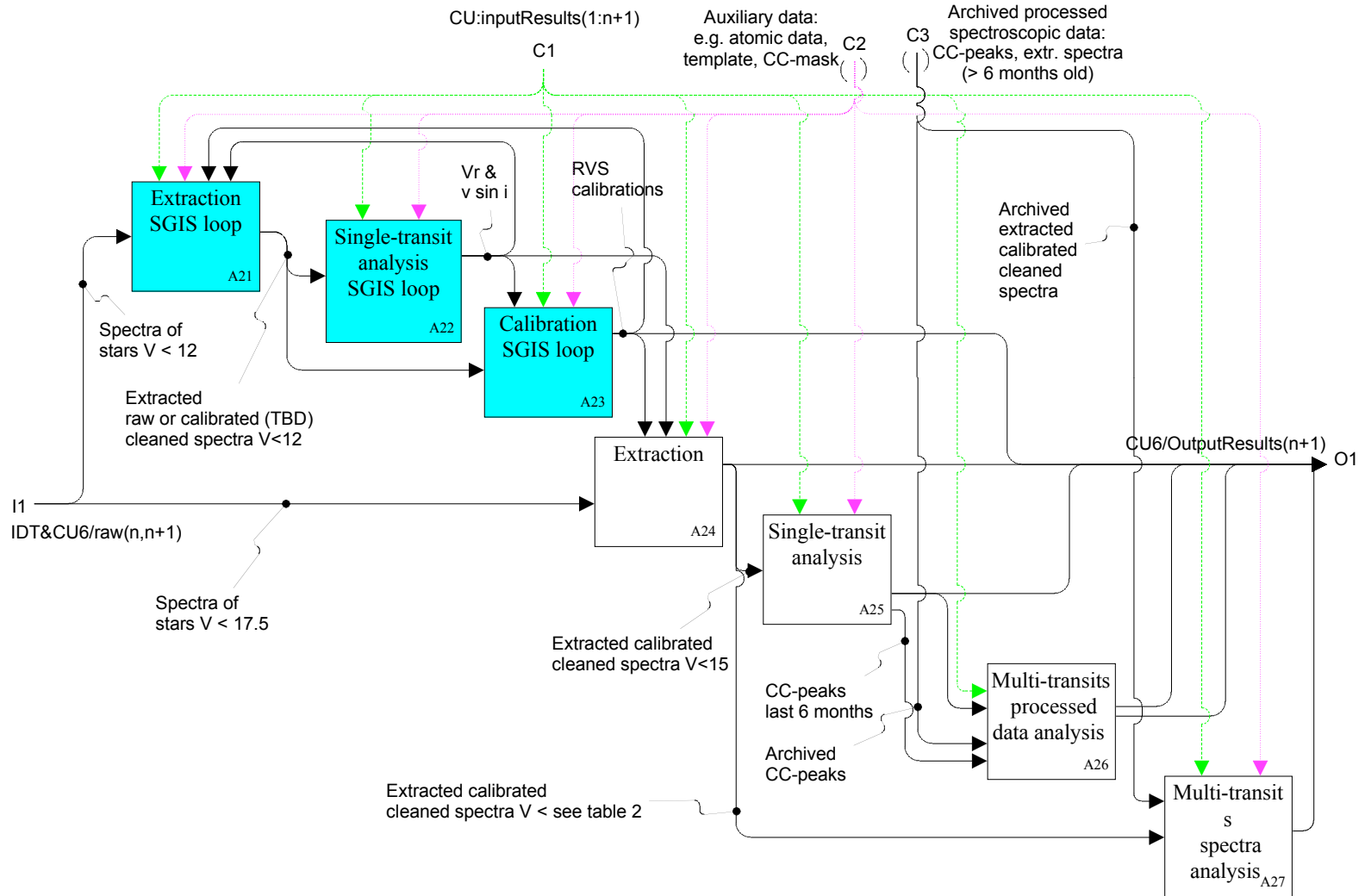

Paris, 6-7 mars 2006